

Ranch Showmanship: W/T, Novice – 108, 109, 110

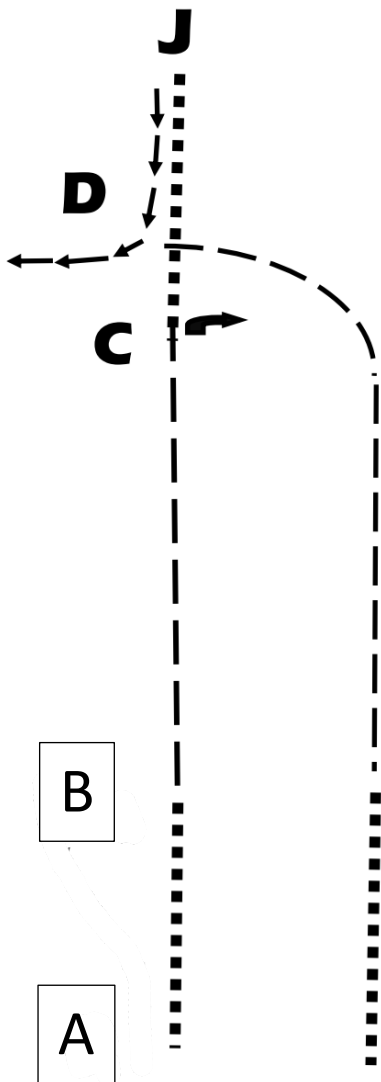

Set up at A

1. Walk to B
2. Trot to C
3. Walk to Judge
4. Set up for inspection
5. Back between C and D
6. Trot to B
7. At B, break to walk and exit

Ranch Showmanship: Youth, Amateur – 111, 112

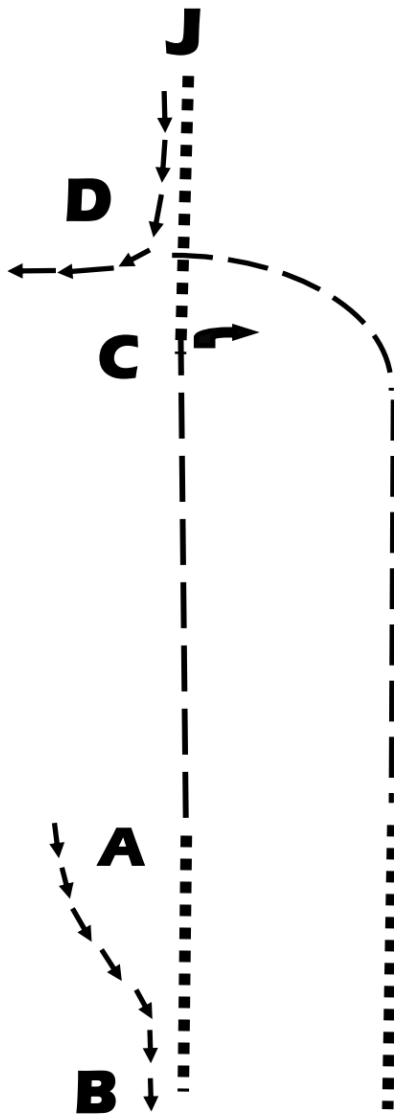

1. Set-up at A on left side of cone
2. Back to right side of B.
3. Walk to A
4. At A trot to C
5. At C Stop; 360°
6. Walk to Judge
7. Set up for Inspection
8. Back between C - D
9. Trot back to A
10. At A break to a walk; exit pen

Ranch Riding – 113.W/T Youth, 114.W/T Amateur

Ranch Riding Pattern #5

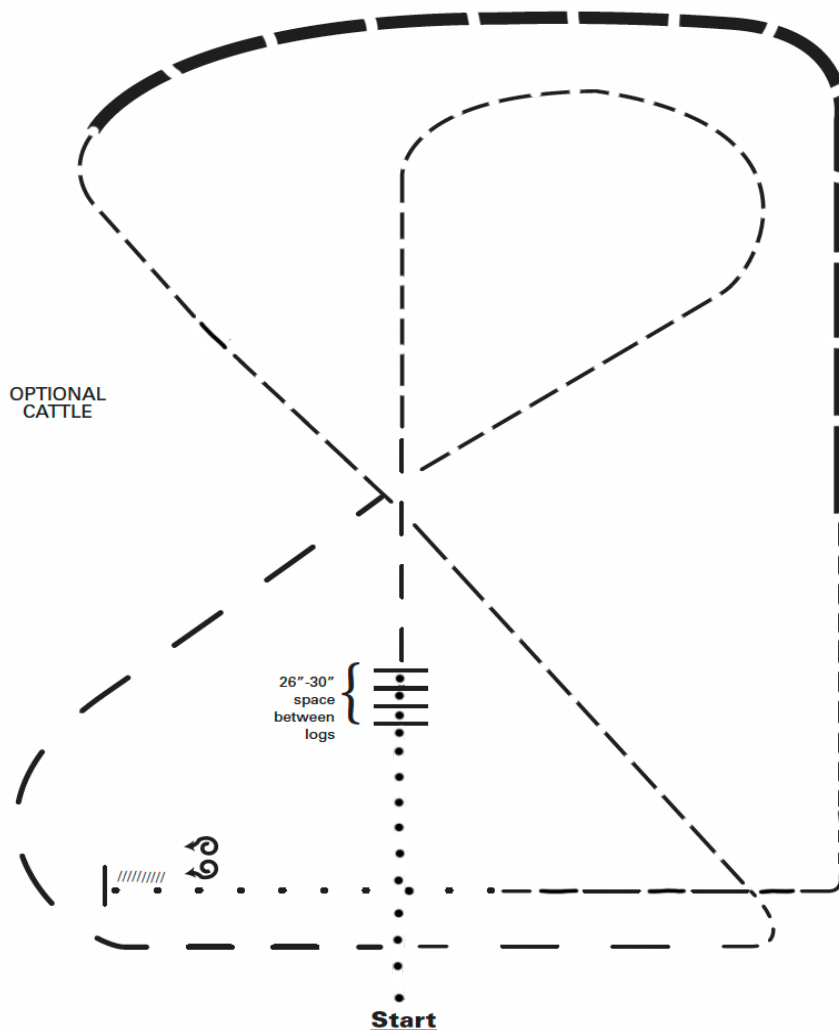

1. Walk
2. Walk over logs
3. Trot
4. Extended trot
5. Trot
6. Extended trot
7. Collected trot
8. Trot
9. Walk
10. Stop and back
11. 360 degree turn each direction (either way first) (L-R or R-L)

Ranch Riding – 115.Novice, 116.Youth, 117.Green
120.APHA Youth, 121.APHA Nov. Amateur

Ranch Riding Pattern #5

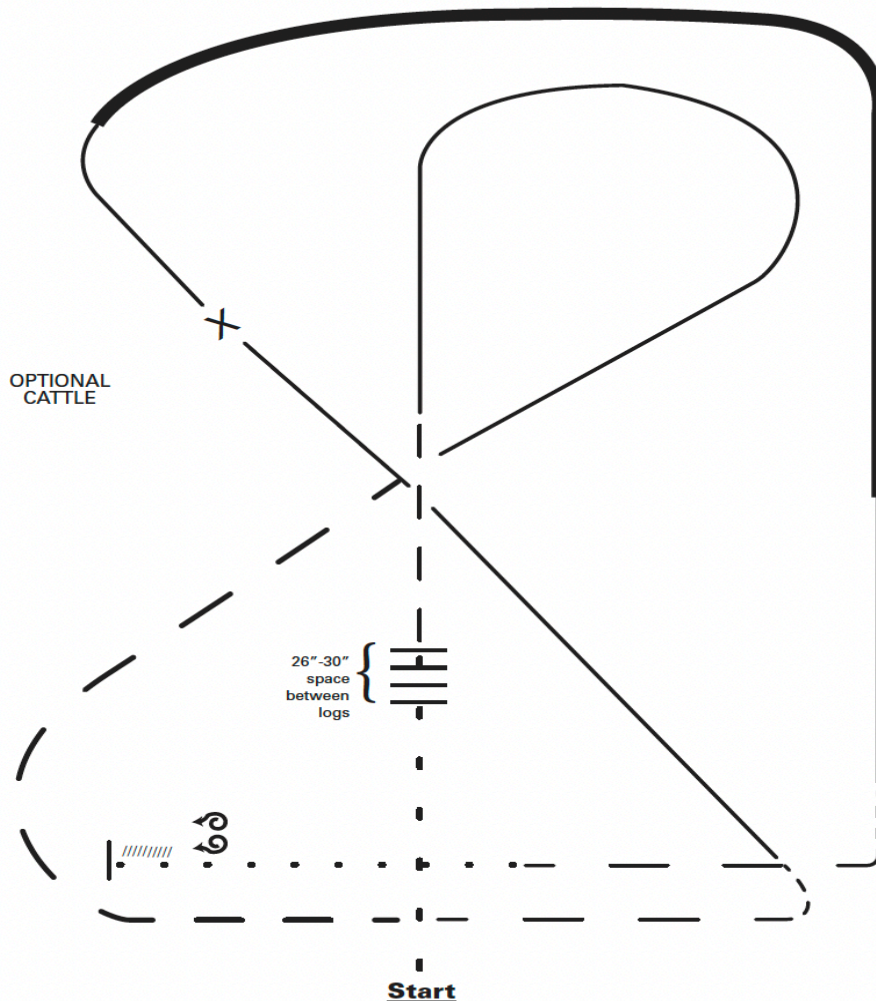

1. Walk
2. Walk over logs
3. Trot
4. Lope right lead
5. Extended trot
6. Trot
7. Lope left lead
8. Change leads (simple or flying)
9. Extended lope (right lead)
10. Collect Lope
11. Trot
12. Walk
13. Stop and back
14. 360 degree turn each direction (either direction 1st) (L-R or R-L)

Ranch Riding – 118.Amateur, 119.Open, 122.APHA Amateur
123. APHA All Ages

Ranch Riding Pattern #1

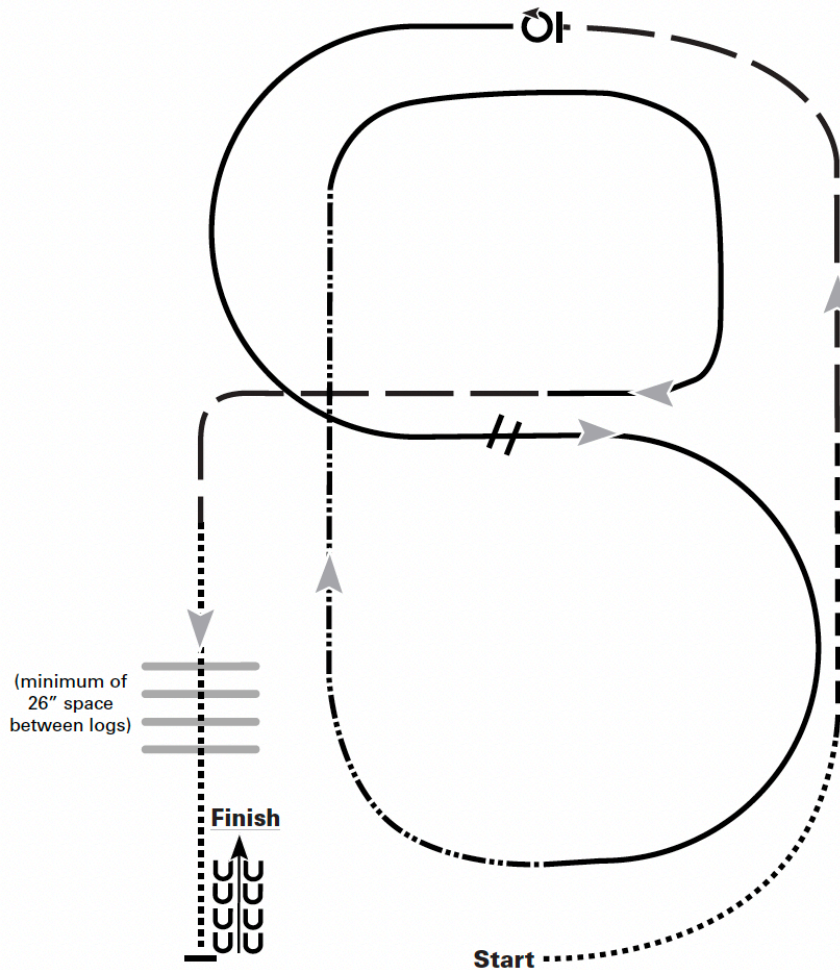

1. Walk
2. Trot
3. Extend the trot ,at the top of the arena, stop
4. 360 turn to the left
5. Left lead ½ circle, lope to the center
6. Change leads (simple or flying)
7. Right lead ½ circle
8. Extended lope up the long side of the arena (right lead)
9. Collect back to a lope around the top of the arena and back to center
10. Break down to an extended trot
11. Walk over poles
12. Stop and back

Ranch Horsemanship – 124.W/T Youth, 125.W/T Amateur

1. Start at cone, trot over poles to the center of arena and stop.
2. 1 spin right.
3. Extended Trot over pole and down arena, stop, Roll back left.
4. Trot circle left
5. In middle transition to a walk, walk 10 to 15 feet.
6. Stop; back 8-10 feet, 90° turn to left; and trot out of arena.

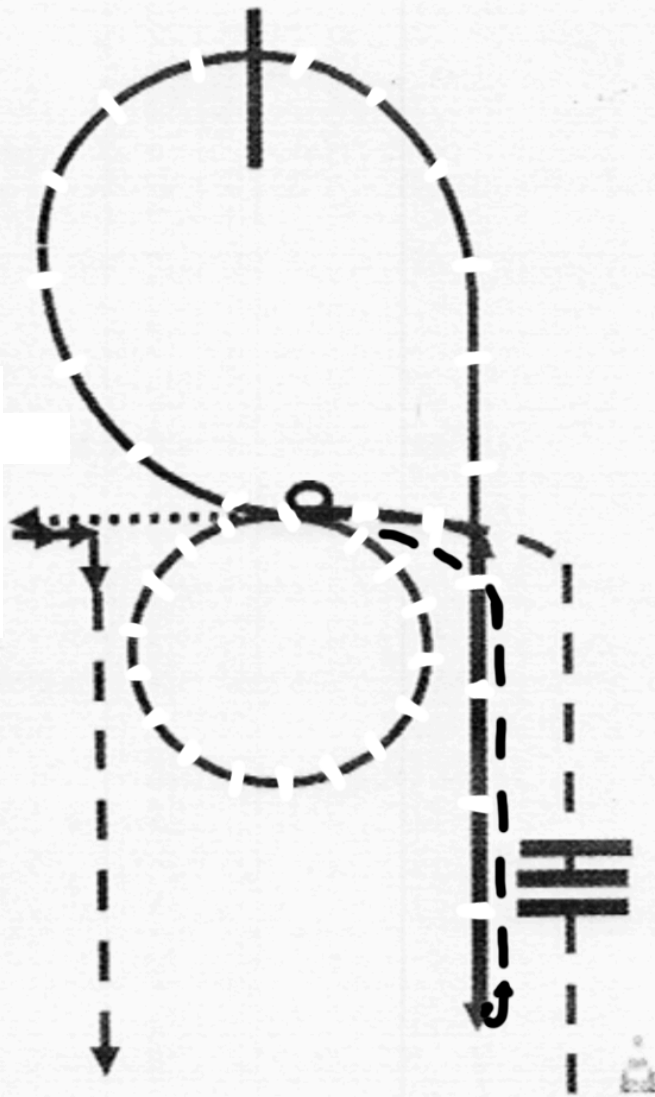

Ranch Horsemanship – 126. Novice, 127. Youth, 128. Amateur

1. Start at cone, trot over poles to the center of arena and stop.
2. 1 spin right.
3. Right lead lope over pole and run-down arena, stop, roll back to left.
4. Left lead lope small slow.
5. In middle transition to a walk, walk 10 to 15 feet.
6. Stop; back 8-10 feet, 90° turn to left; and trot out of arena.

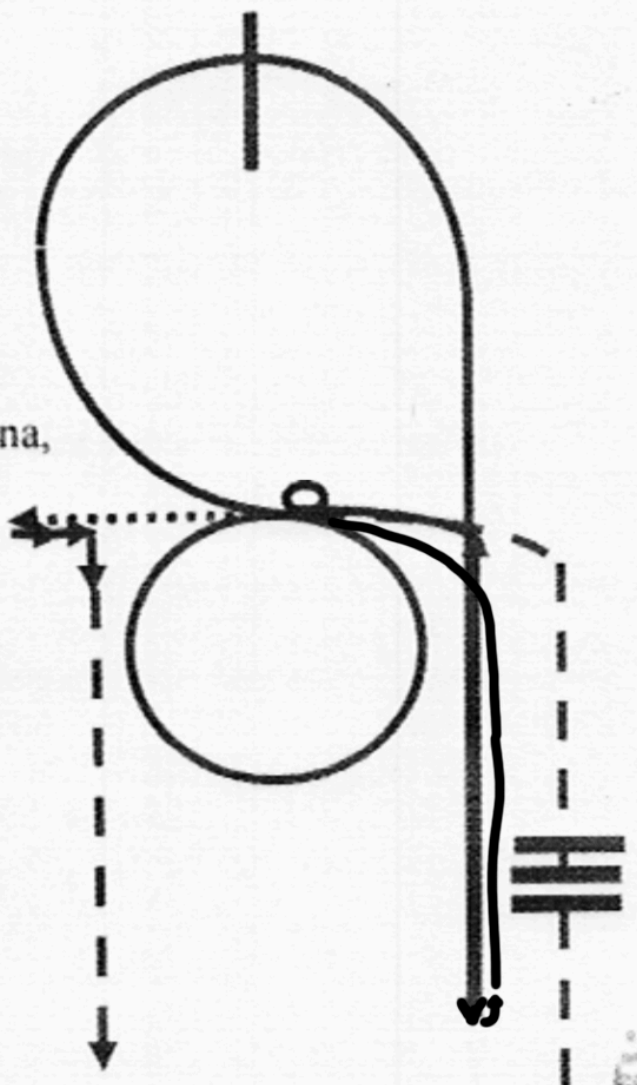

Ranch Horse Reining Pattern #4

129. Ranch Reining, W/T Youth 18 & Under
130. Ranch Reining, W/T Amateur

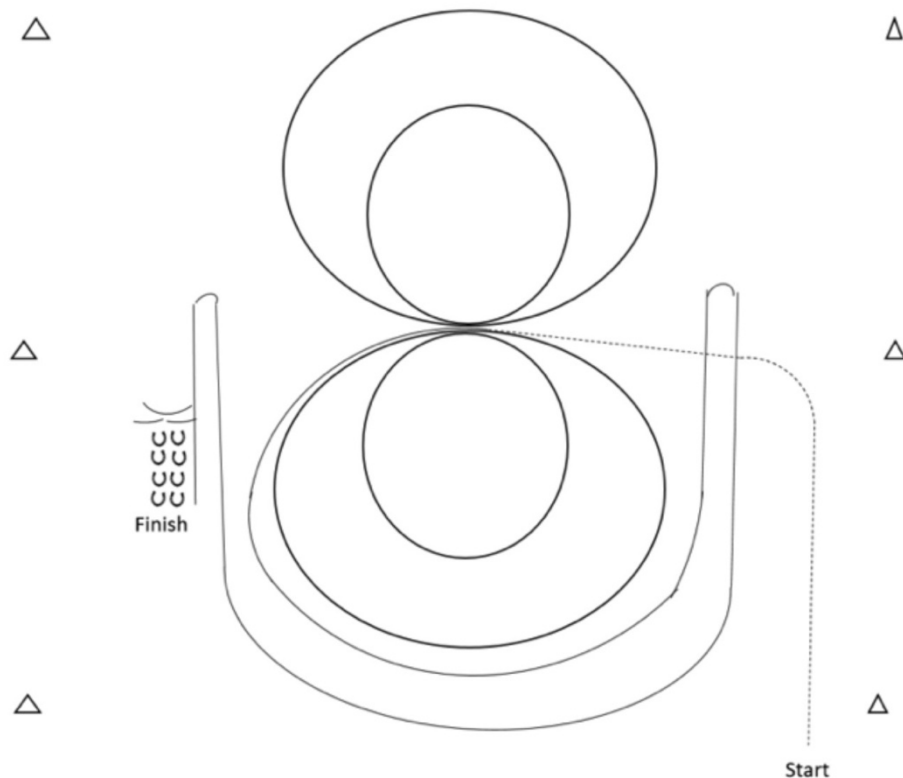

1. Beginning to the left, jog two circles to the left, the first circle small and slow, the next circle large and fast,
2. Complete two circles to the right, the first circle small and slow, the next circle large and fast.
3. Begin large circle to left, but do not close the circle, extend jog down the right side of the arena past center marker, and roll back right, no hesitation.
4. Continue around the end of the arena to extend jog down the left side of the arena past center marker and do a left roll back, no hesitation.
5. Extend jog past the middle marker, Stop, Back up 10 feet, 1/4 turn to right, 1/2 turn to left, 1/4 turn to Right. Hesitate to complete pattern.

Ranch Horse Reining Pattern #1

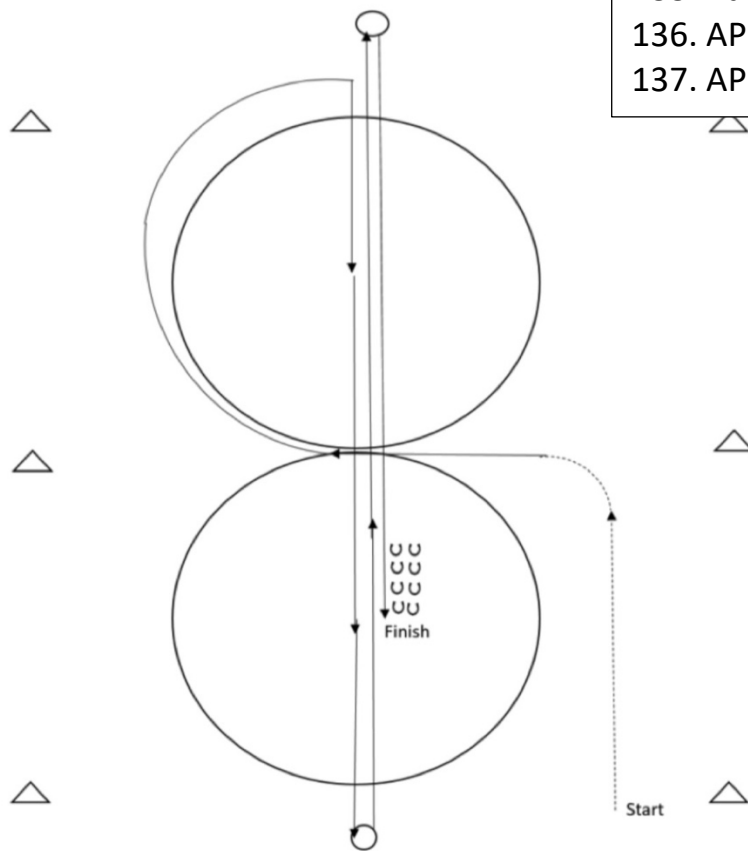

131. Ranch Reining, Novice Rider All Ages
132 Ranch Reining, Youth 18 & Under
133. Ranch Reining, Green Horse
136. APHA Ranch Reining, Youth 18 & Under
137. APHA Ranch Reining, Novice Amateur

Trot to center of Arena , Stop. Start pattern facing towards Judge.

1. Beginning on the right lead Lope one circle to the right, Change Leads to the left.
2. Complete one circle to the left, Change leads to the right and go to the top of arena.
3. Run down center of arena past the end marker and come to stop.
4. Complete 1 1/2 spins to right
5. Run to the other end of the arena, past the end marker and come to a stop.
6. Complete 1 1/2 spins to the left. Run past the center marker, stop, back 10 feet.
7. Hesitate to complete pattern.

Ranch Horse Reining Pattern #2

134. Ranch Reining, Amateur
135. Ranch Reining, Open
138. APHA Ranch Reining, Amateur
139. APHA Ranch Reining, All Ages

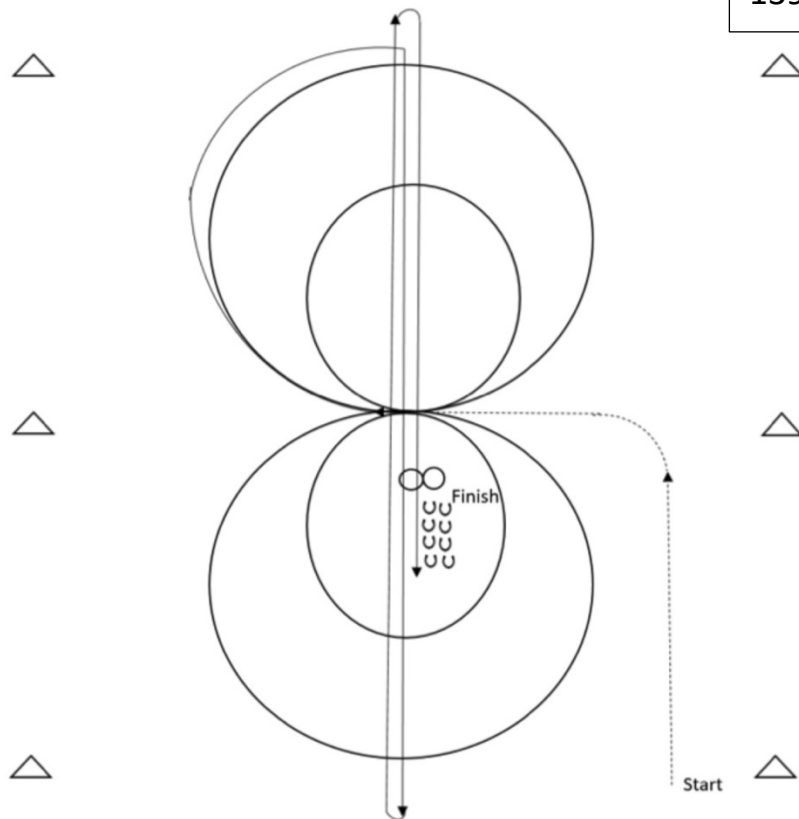

Trot to center of Arena , Stop. Start pattern facing towards Judge.

1. Beginning on the right lead complete two circle to the right, The first circle small and slow, the next circle large and fast, Change leads at the center of arena.
2. Complete two circles to the left, The first circle small and slow, the next circle large and fast, Change leads in the center of the arena.
3. Begin large circle to right, but do not close the circle. Run down center of arena past the end marker and do a right roll back, no hesitation.
4. Run up the middle to the other end of the arena past the end marker and do a left roll back, no hesitation.
5. Run past the center marker, stop, back 10 feet.
6. 1 spin to right, 1 spin to left. Hesitate to complete pattern.

Ranch Pleasure

The purpose of the ranch horse pleasure class is to measure the ability of the horse to be a pleasure to ride while being used as a means of conveyance from performing one ranch task to another. The horse should reflect the versatility, attitude and movement of a working ranch horse riding outside the confines of an arena. The horse should be well-trained, relaxed, quiet, soft and cadenced at all gaits. The ideal ranch horse will travel with forward movement and demonstrate an obvious lengthening of stride at extended gaits. The horse can be ridden with light contact or on a relatively loose rein without requiring undue restraint, but not shown on a full drape of reins. The overall manners and responsiveness of the ranch pleasure horse to make timely transitions in a smooth and correct manner, as well as the quality of the movement are of primary considerations. The ideal Ranch pleasure horse should have a natural head carriage at each gait. Horses shall be shown individually. Markers shall be set up to designate gait changes.

Start to the left of in gate on the right track.

W/T Ranch Pleasure

156, 157

PATTERN II (modified)
Ordinary Walk- 100 feet
Trot – 150 feet
Extended Trot – 200 feet
Ordinary Walk – 50 feet
Stop and Reverse
Extended Walk – 50 feet
Extended Trot – 200 feet
Trot – 150 feet
Ordinary Walk – 100 feet
Stop and Back

Ranch Pleasure

All Other

PATTERN II
Ordinary Walk- 30 feet
Lope – 150 feet
Extended Lope – 200 feet
Trot – 120 feet
Stop and Reverse
Extended Walk – 75 feet
Trot – 90 feet
Extended Trot – 240 feet
Lope – 150 feet
Stop and Back

Ranch Trail: Walk Trot - 167, 168

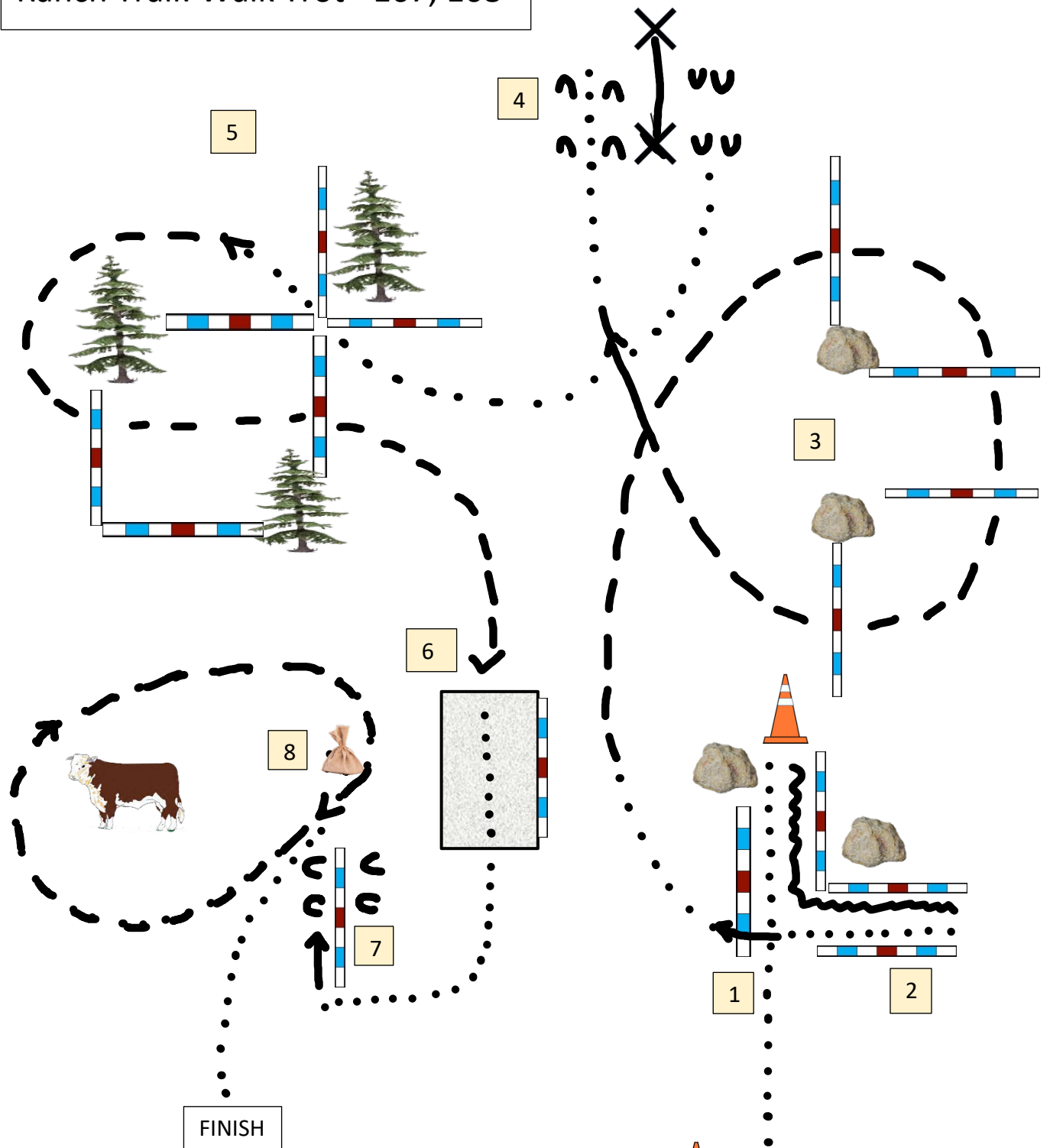

START between cones

1. Walk into chute and Stop
2. Back L, walk out over pole
3. Trot over poles, walk up to gate
4. Pass thru gate, R hand push
5. Walk over X then jog over poles as shown to bridge

6. Walk over bridge

7. Sidepass pole to right.
8. Jog circle around animal
Walk out and finish



Ranch Trail: Novice, Youth, Green - 169, 170, 171, 174, 175

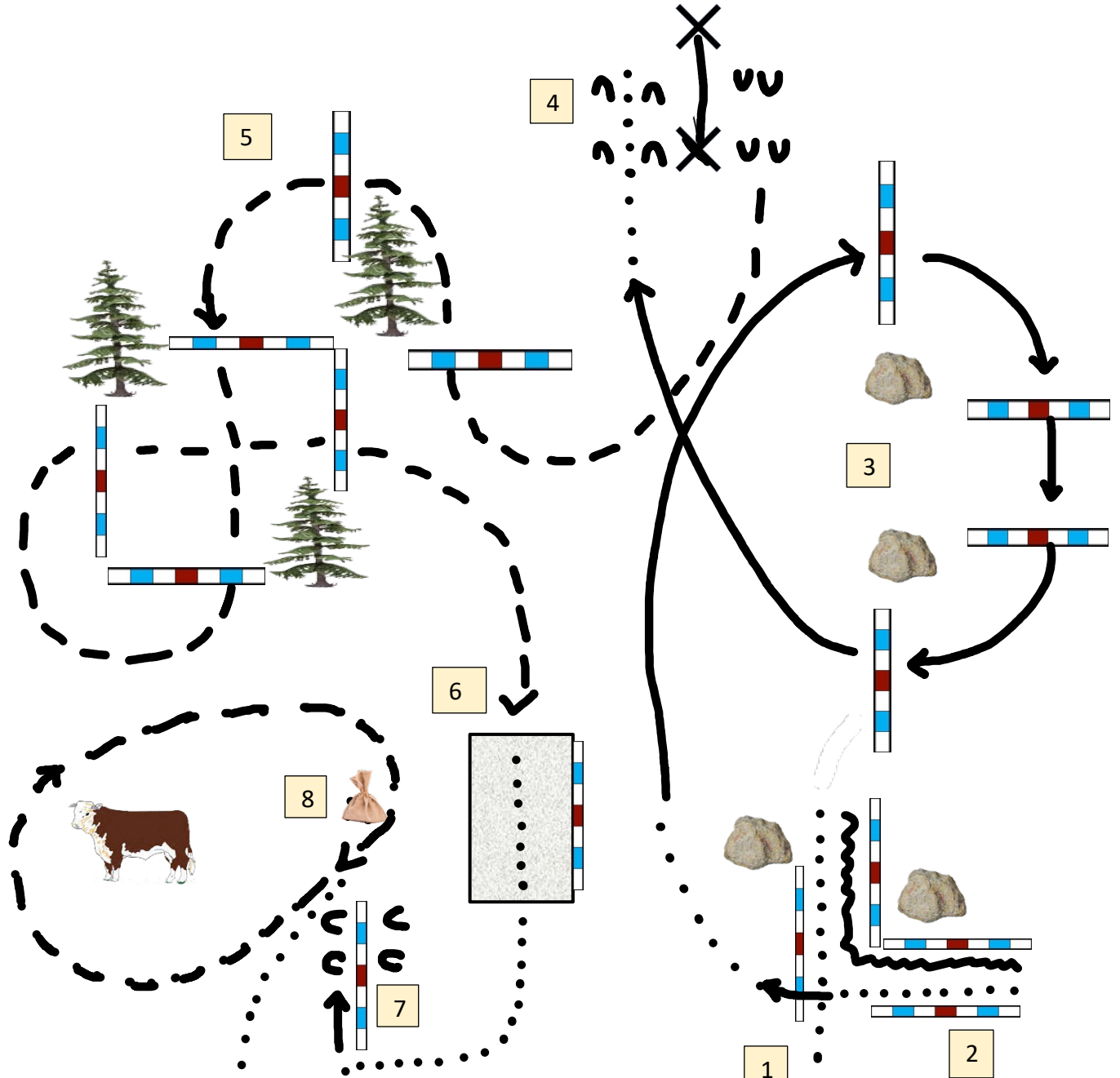

START between cones

1. Walk into chute and Stop
 2. Back L, walk out over pole
 3. Lope over poles, walk up to gate
 4. Pass thru gate, R hand push
 5. Jog over poles as shown to bridge
 6. Walk over bridge
 7. Sidepass pole to right.
 8. Jog circle around animal
- Walk out and finish

FINISH

START

Ranch Trail: Amateur, Open, All Ages - - 172, 173, 176, 177

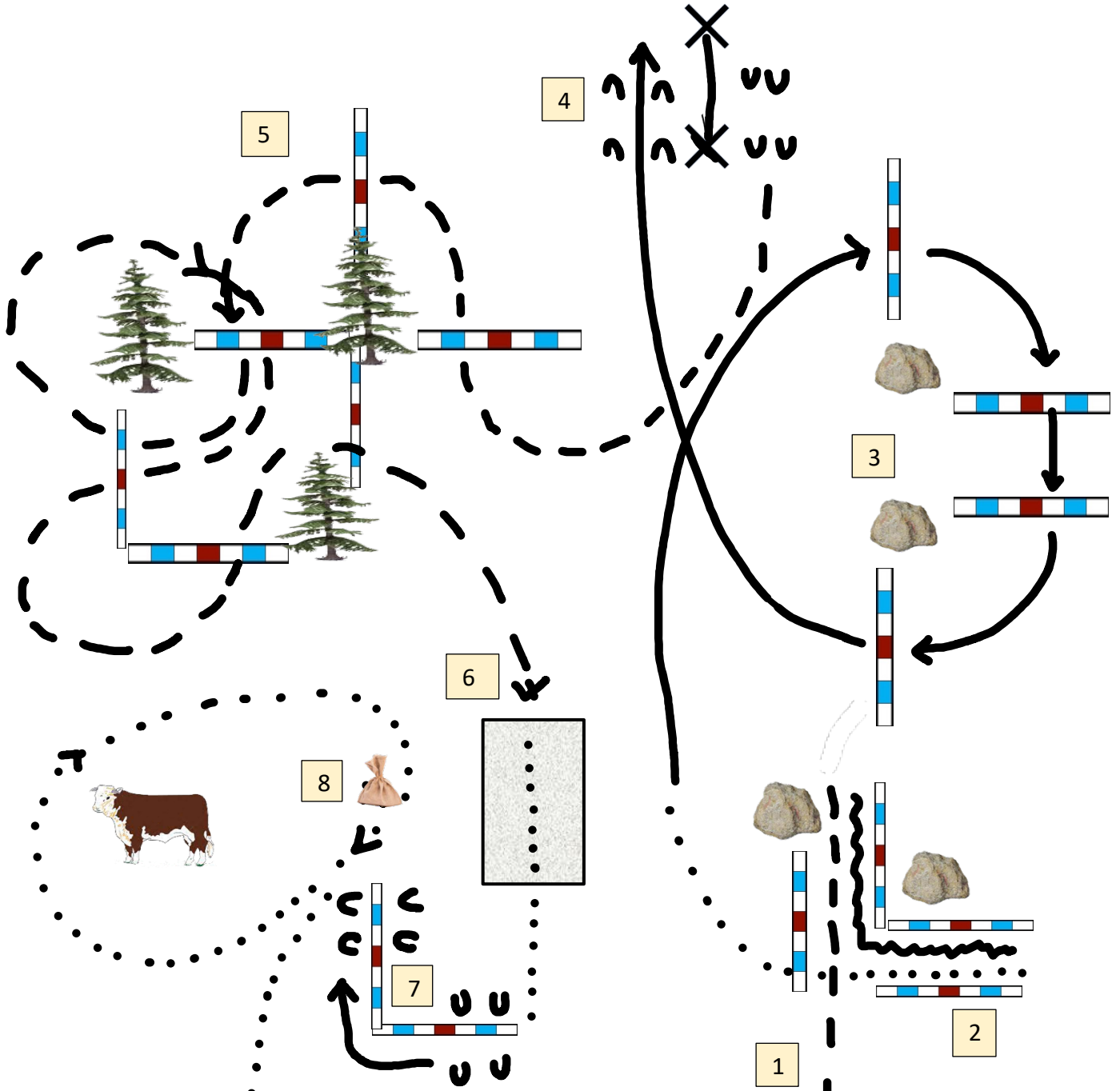

FINISH

START between cones

1. Jog into chute and Stop
2. Back L, walk out over pole
3. Lope over poles up to gate
4. Pass thru gate, R hand push
5. Jog over poles as shown to bridge
6. Walk over bridge
7. Sidepass L up to drag.
8. Drag sack around animal and return. Walk out and finish

START